

DESCRIPTION

The SG1842/43 family of control IC's provides all the necessary features to implement off-line fixed frequency, current-mode switching power supplies with a minimum number of external components. Current-mode architecture demonstrates improved line regulation, improved load regulation, pulse-by-pulse current limiting and inherent protection of the power supply output switch. The bandgap reference is trimmed to $\pm 1\%$ over temperature. Oscillator discharge current is trimmed to less than $\pm 10\%$. The SG1842/43 has under-voltage

lockout, current limiting circuitry and start-up current of less than 1mA. The totem-pole output is optimized to drive the gate of a power MOSFET. The output is low in the off state to provide direct interface to an N channel device. The SG1842/43 is specified for operation over the full military ambient temperature range of -55°C to 125°C . The SG2842/43 is specified for the industrial range of -25°C to 85°C , and the SG3842/43 is designed for the commercial range of 0°C to 70°C .

IMPORTANT: For the most current data, consult MICROSEMI's website: <http://www.microsemi.com>

KEY FEATURES

- OPTIMIZED FOR OFF-LINE CONTROL
- LOW START-UP CURRENT ($<1\text{mA}$)
- AUTOMATIC FEED FORWARD COMPENSATION
- TRIMMED OSCILLATOR DISCHARGE CURRENT
- PULSE-BY-PULSE CURRENT LIMITING
- ENHANCED LOAD RESPONSE CHARACTERISTICS
- UNDER-VOLTAGE LOCKOUT WITH 6V HYSTERESIS (SG1842 only)
- DOUBLE-PULSE SUPPRESSION
- HIGH-CURRENT TOTEM-POLE OUTPUT (1AMP PEAK)
- INTERNALLY TRIMMED BANDGAP REFERENCE
- 500KHZ OPERATION
- UNDERVOLTAGE LOCKOUT
SG1842 - 16 volts
SG1843 - 8.4 volts
- LOW SHOOT-THROUGH CURRENT $<75\text{mA}$ OVER TEMPERATURE

PRODUCT HIGHLIGHT

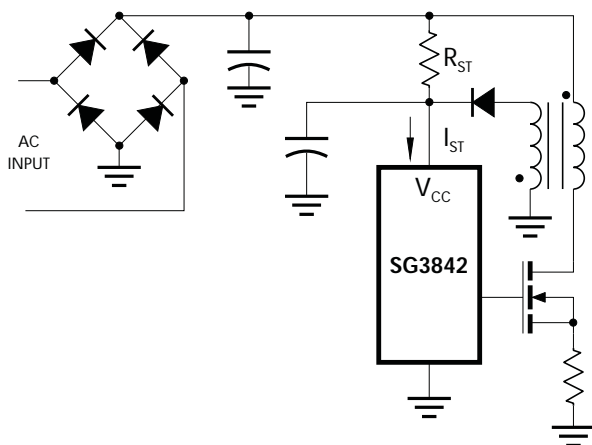

HIGH RELIABILITY FEATURES

- AVAILABLE TO MIL-STD-883B AND DESC SMD
- SCHEDULED FOR MIL-M38510 QPL LISTING
- RADIATION DATA AVAILABLE
- LINFINITY LEVEL "S" PROCESSING AVAILABLE

PACKAGE ORDER INFO

T _A (°C)	M	N	DM	D	Y	J	F	L
	Plastic DIP 8-Pin RoHS / Pb-free Transition DC: 0503	Plastic DIP 14-Pin	Plastic SOIC 8-Pin RoHS / Pb-free Transition DC:0440	Plastic SOIC 14-Pin	Ceramic Dip 8-Pin	Ceramic DIP 14-Pin	Cer Flatpack 10-Pin	Ceramic LCC 20-Pin
0 to 70	SG3842M	SG3842N	SG3842DM	SG3842D	SG3842Y	SG3842J		
	SG3843M	SG3843N	SG3843DM	SG3843D	SG3843Y	SG3842J		
-25 to 85	SG2842M	SG2842N	SG2842DM	SG2842D	SG2842Y	SG2842J		
	SG2843M	SG2843N	SG2843DM	SG2843D	SG2843Y	SG2843J		
-55 to 125					SG1842Y	SG1842J		SG1842L
					SG1843Y	SG1843J		SG1842L
MIL-STD/883					SG1842Y/883B	SG1842J/883B		SG1842L/883B
					SG1843Y/883B	SG1843J/883		SG1843L/883B
DESC					SG1842Y/DESC	SG1842J/DESC	SG1842F/DESC	SG1842L/DESC

Note: Available in Tape & Reel. Append the letters "TR" to the part number. (i.e. SG2843DM-TR)

RoHS compliant

SG1842/SG1843 Series

CURRENT-MODE PWM CONTROLLER

PRODUCTION DATA SHEET

ABSOLUTE MAXIMUM RATINGS (Notes 1 & 2)

Supply Voltage ($I_{CC} < 30\text{mA}$)	Self Limiting
Supply Voltage (Low Impedance Source)	30V
Output Current (Peak)	$\pm 1\text{A}$
Output Current (Continuous)	350mA
Output Energy (Capacitive Load)	5 μJ
Analog Inputs (Pins 2, 3)	-0.3V to +6.3V
Error Amp Output Sink Current	10mA
Power Dissipation at $T_A = 25^\circ\text{C}$ (DIL-8)	1W
Operating Junction Temperature	
Hermetic (J, Y, F, L Packages)	150 $^\circ\text{C}$
Plastic (N, M, D, DM Packages)	150 $^\circ\text{C}$
Storage Temperature Range	-65 $^\circ\text{C}$ to +150 $^\circ\text{C}$
Lead Temperature (Soldering, 10 Seconds)	300 $^\circ\text{C}$
Pb-free / RoHS Peak Package Solder Reflow Temp. (40 second max. exposure)	260 $^\circ\text{C}$ (+0, -5)

Note 1. Exceeding these ratings could cause damage to the device.

Note 2. All voltages are with respect to Pin 5. All currents are positive into the specified terminal.

THERMAL DATA

M PACKAGE:

THERMAL RESISTANCE-JUNCTION TO AMBIENT, θ_{JA}	95 $^\circ\text{C/W}$
---	-----------------------

N PACKAGE:

THERMAL RESISTANCE-JUNCTION TO AMBIENT, θ_{JA}	65 $^\circ\text{C/W}$
---	-----------------------

DM PACKAGE:

THERMAL RESISTANCE-JUNCTION TO AMBIENT, θ_{JA}	165 $^\circ\text{C/W}$
---	------------------------

D PACKAGE:

THERMAL RESISTANCE-JUNCTION TO AMBIENT, θ_{JA}	120 $^\circ\text{C/W}$
---	------------------------

Y PACKAGE:

THERMAL RESISTANCE-JUNCTION TO AMBIENT, θ_{JA}	130 $^\circ\text{C/W}$
---	------------------------

J PACKAGE:

THERMAL RESISTANCE-JUNCTION TO AMBIENT, θ_{JA}	80 $^\circ\text{C/W}$
---	-----------------------

F PACKAGE:

THERMAL RESISTANCE-JUNCTION TO CASE, θ_{JC}	80 $^\circ\text{C/W}$
THERMAL RESISTANCE-JUNCTION TO AMBIENT, θ_{JA}	145 $^\circ\text{C/W}$

L PACKAGE:

THERMAL RESISTANCE-JUNCTION TO CASE, θ_{JC}	35 $^\circ\text{C/W}$
THERMAL RESISTANCE-JUNCTION TO AMBIENT, θ_{JA}	120 $^\circ\text{C/W}$

Junction Temperature Calculation: $T_J = T_A + (P_D \times \theta_{JA})$.

The θ_{JA} numbers are guidelines for the thermal performance of the device/pc-board system. All of the above assume no ambient airflow.

PACKAGE PIN OUTS

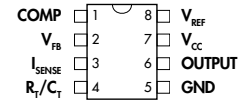

M & Y PACKAGE

(Top View)

M Package: Pb-free / RoHS 100% Matte Tin Lead Finish

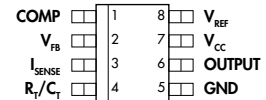

DM PACKAGE

(Top View)

Pb-free / RoHS 100% Matte Tin Lead Finish

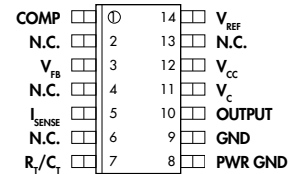

D PACKAGE

(Top View)

Pb-free / RoHS 100% Matte Tin Lead Finish

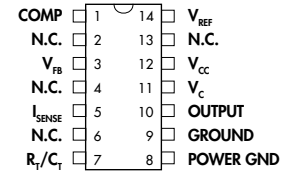

J & N PACKAGE

(Top View)

N Package: Pb-free / RoHS 100% Matte Tin Lead Finish

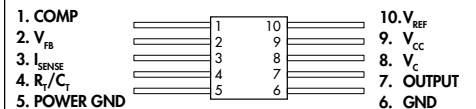

F PACKAGE

(Top View)

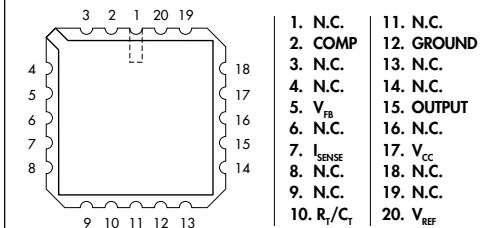

L PACKAGE

(Top View)

CURRENT-MODE PWM CONTROLLER

PRODUCTION DATA SHEET

RECOMMENDED OPERATING CONDITIONS (Note 3)

Parameter	Symbol	Recommended Operating Conditions			Units
		Min.	Typ.	Max.	
Supply Voltage Range			30		V
Output Current (Peak)			±1		A
Output Current (Continuous)			200		mA
Analog Inputs (Pin 2, Pin 3)		0		2.6	V
Error Amp Output Sink Current			5		mA
Oscillator Frequency Range		0.1		500	kHz
Oscillator Timing Resistor	R_T	0.52		150	K Ω
Oscillator Timing Capacitor	C_T	0.001		1.0	μ F
Operating Ambient Temperature Range:					
SG1842/43		-55		125	$^{\circ}$ C
SG2842/43		-25		85	$^{\circ}$ C
SG3842/43		0		70	$^{\circ}$ C

Note 3. Range over which the device is functional.

ELECTRICAL CHARACTERISTICS

(Unless otherwise specified, these specifications apply over the operating ambient temperatures for SG1842/SG1843 with $-55^{\circ}\text{C} \leq T_A \leq 125^{\circ}\text{C}$, SG2842/SG2843 with $-25^{\circ}\text{C} \leq T_A \leq 85^{\circ}\text{C}$, SG3842/SG3843 with $0^{\circ}\text{C} \leq T_A \leq 70^{\circ}\text{C}$, $V_{CC} = 15\text{V}$ (Note 7), $R_T = 10\text{k}\Omega$, and $C_T = 3.3\text{nF}$. Low duty cycle pulse testing techniques are used which maintains junction and case temperatures equal to the ambient temperature.)

Parameter	Symbol	Test Conditions	SG1842/43			SG2842/43			SG3842/43			Units
			Min.	Typ.	Max.	Min.	Typ.	Max.	Min.	Typ.	Max.	
Reference Section												
Output Voltage		$T_J = 25^{\circ}\text{C}, I_O = 1\text{mA}$	4.95	5.00	5.05	4.95	5.00	5.05	4.90	5.00	5.10	V
Line Regulation		$12 \leq V_{IN} \leq 25\text{V}$		6	20		6	20		6	20	mV
Load Regulation		$1 \leq I_O \leq 20\text{mA}$		6	25		6	25		6	25	mV
Temperature Stability (Note 4)				0.2	0.4		0.2	0.4		0.2	0.4	mV/ $^{\circ}$ C
Total Output Variation (Note 4)		Line, Load, Temp.	4.90		5.10	4.90		5.10	4.82		5.18	V
Output Noise Voltage (Note 4)	V_N	$10\text{Hz} \leq f \leq 10\text{kHz}, T_J = 25^{\circ}\text{C}$		50			50			50		μ V
Long Term Stability (Note 4)		$T_A = 125^{\circ}\text{C}, 1000\text{hrs}$		5	25		5	25		5	25	mV
Output Short Circuit			-30	-100	-180	-30	-100	-180	-30	-100	-180	mA
Oscillator Section												
Initial Accuracy		$T_J = 25^{\circ}\text{C}$	47	52	57	47	52	57	47	52	57	kHz
Voltage Stability		$12 \leq V_{CC} \leq 25\text{V}$		0.2	1		0.2	1		0.2	1	%
Temperature Stability (Note 4)		$T_{MIN} \leq T_A \leq T_{MAX}$		5			5			5		%
Amplitude		$V_{RT/CT}$ (Peak to Peak)		1.7			1.7			1.7		V
Discharge Current		$T_J = 25^{\circ}\text{C}$	7.8	8.3	8.8	7.5	8.4	9.3	7.5	8.4	9.3	mA
		$T_{MIN} \leq T_A \leq T_{MAX}$	7.0		9.0	7.2		9.5	7.2		9.5	mA
Error Amp Section												
Input Voltage		$V_{COMP} = 2.5\text{V}$	2.45	2.50	2.55	2.45	2.50	2.55	2.42	2.50	2.58	V
Input Bias Current				-0.3	-1		-0.3	1		-0.3	-2	μ A
Open Loop Gain	A_{VOL}	$2 \leq V_O \leq 4\text{V}$	65	90		65	90		65	90		dB
Unity Gain Bandwidth (Note 4)		$T_J = 25^{\circ}\text{C}$	0.7	1		0.7	1		0.7	1		MHz
Power Supply Rejection Ratio	PSRR	$12 \leq V_{CC} \leq 25\text{V}$	60	70		60	70		60	70		dB
Output Sink Current		$V_{VFB} = 2.7\text{V}, V_{COMP} = 1.1\text{V}$	2	6		2	6		2	6		mA
Output Source Current		$V_{VFB} = 2.3\text{V}, V_{COMP} = 5\text{V}$	-0.5	-0.8		-0.5	-0.8		-0.5	-0.8		mA
V_{OUT} High		$V_{VFB} = 2.3\text{V}, R_L = 15\text{K to gnd}$	5	6		5	6		5	6		V
V_{OUT} Low		$V_{VFB} = 2.7\text{V}, R_L = 15\text{K to } V_{REF}$		0.7	1.1		0.7	1.1		0.7	1.1	V

(Electrical Characteristics continue next page.)

SG1842/SG1843 Series

CURRENT-MODE PWM CONTROLLER

PRODUCTION DATA SHEET

ELECTRICAL CHARACTERISTICS (Cont'd.)

Parameter	Symbol	Test Conditions	SG1842/43			SG2842/43			SG3842/43			Units
			Min.	Typ.	Max.	Min.	Typ.	Max.	Min.	Typ.	Max.	
Current Sense Section												
Gain (Notes 5 & 6)			2.85	3	3.15	2.85	3	3.15	2.85	3	3.15	V/V
Maximum Input Signal (Note 5)		$V_{COMP} = 5V$	0.9	1	1.1	0.9	1	1.1	0.9	1	1.1	V
Power Supply Rejection Ratio (Note 5)	PSRR	$12 \leq V_{CC} \leq 25V$		70			70			70		dB
Input Bias Current				-2	-10		-2	-10		-2	-10	μA
Delay to Output (Note 4)				150	300		150	300		150	300	ns
Output Section												
Output Low Level		$I_{SINK} = 20mA$		0.1	0.4		0.1	0.4		0.1	0.4	V
		$I_{SINK} = 200mA$		1.5	2.2		1.5	2.2		1.5	2.2	V
Output High Level		$I_{SOURCE} = 20mA$	13	13.5		13	13.5		13	13.5		V
		$I_{SOURCE} = 200mA$	12	13.5		12	13.5		12	13.5		V
Rise Time		$T_J = 25^\circ C, C_L = 1nF$		50	150		50	150		50	150	ns
Fall Time		$T_J = 25^\circ C, C_L = 1nF$		50	150		50	150		50	150	ns
Under-Voltage Lockout Section												
Start Threshold		1842	15	16	17	15	16	17	14.5	16	17.5	V
		1843	7.8	8.4	9.0	7.8	8.4	9.0	7.8	8.4	9.0	V
Min. Operation Voltage After Turn-On		1842	9	10	11	9	10	11	8.5	10	11.5	V
		1843	7.0	7.6	8.3	7.0	7.6	8.2	7.0	7.6	8.2	V
PWM Section												
Maximum Duty Cycle			93	95	100	90	95	100	90	95	100	%
Minimum Duty Cycle					0			0			0	%
Power Consumption Section												
Start-Up Current				0.5	1		0.5	1		0.5	1	mA
Operating Supply Current		$V_{FB} = V_{ISENSE} = 0V$		11	17		11	17		11	17	mA
V_{CC} Zener Voltage		$I_{CC} = 25mA$		34			34			34		V

Notes: 4. These parameters, although guaranteed, are not 100% tested in production.

5. Parameter measured at trip point of latch with $V_{VFB} = 0$.

6. Gain defined as: $A = \frac{\Delta V_{COMP}}{\Delta V_{ISENSE}}$; $0 \leq V_{ISENSE} \leq 0.8V$.

7. Adjust V_{CC} above the start threshold before setting at 15V.

CURRENT-MODE PWM CONTROLLER

PRODUCTION DATA SHEET

BLOCK DIAGRAM

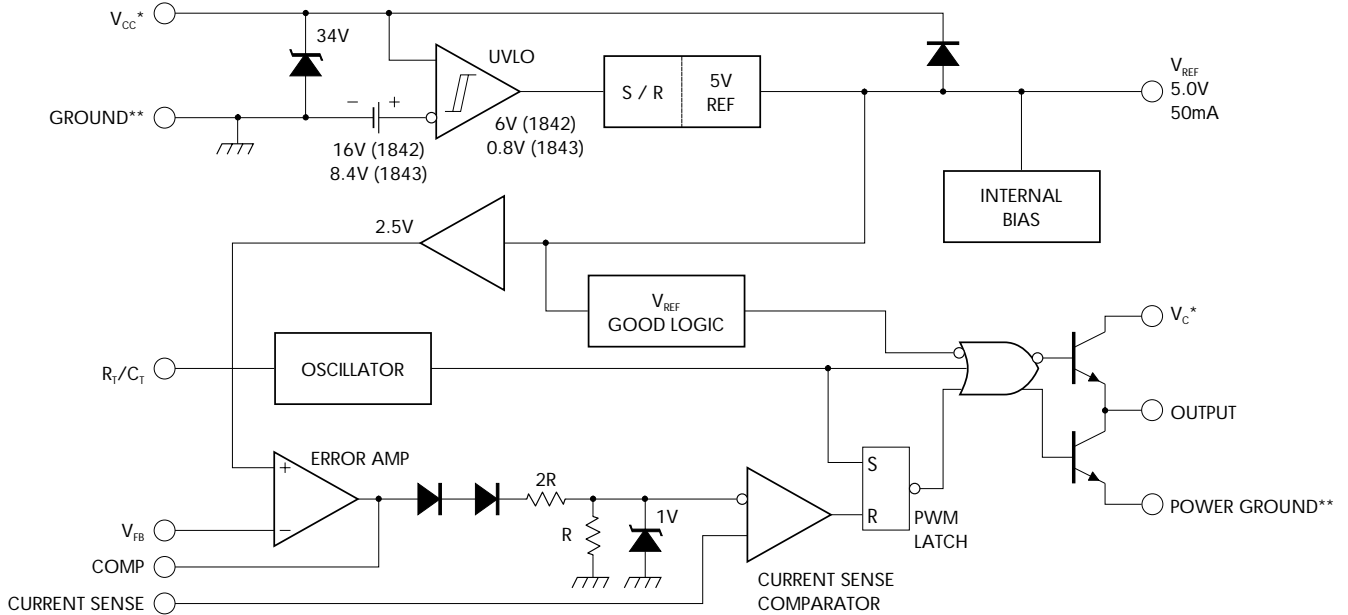

* - V_{CC} and V_C are internally connected for 8 pin packages.

** - POWER GROUND and GROUND are internally connected for 8 pin packages.

GRAPH / CURVE INDEX

Characteristic Curves

FIGURE #

1. DROPOUT VOLTAGE vs. TEMPERATURE
2. OSCILLATOR TEMPERATURE STABILITY
3. CURRENT SENSE TO OUTPUT DELAY vs. TEMPERATURE
4. OUTPUT DUTY CYCLE vs. TEMPERATURE
5. START-UP CURRENT vs. TEMPERATURE
6. REFERENCE VOLTAGE vs. TEMPERATURE
7. START-UP VOLTAGE THRESHOLD vs. TEMPERATURE
8. START-UP VOLTAGE THRESHOLD vs. TEMPERATURE
9. OSCILLATOR DISCHARGE CURRENT vs. TEMPERATURE
10. OUTPUT SATURATION VOLTAGE vs. OUTPUT CURRENT AND TEMPERATURE (SINK TRANSISTOR)
11. CURRENT SENSE THRESHOLD vs. ERROR AMPLIFIER OUTPUT
12. OUTPUT SATURATION VOLTAGE vs. OUTPUT CURRENT AND TEMPERATURE (SOURCE TRANSISTOR)

FIGURE INDEX

Application Information

FIGURE #

13. OSCILLATOR TIMING CIRCUIT
14. OSCILLATOR FREQUENCY vs. R_T FOR VARIOUS C_T

Typical Applications Section

FIGURE #

15. CURRENT SENSE SPIKE SUPPRESSION
16. MOSFET PARASITIC OSCILLATIONS
17. BIPOLAR TRANSISTOR DRIVE
18. ISOLATED MOSFET DRIVE
19. ADJUSTABLE BUFFERED REDUCTION OF CLAMP LEVEL WITH SOFTSTART
20. EXTERNAL DUTY CYCLE CLAMP AND MULTI-UNIT SYNCHRONIZATION
21. OSCILLATOR CONNECTION
22. ERROR AMPLIFIER CONNECTION
23. SLOPE COMPENSATION
24. OPEN LOOP LABORATORY FIXTURE
25. OFF-LINE FLYBACK REGULATOR

CURRENT-MODE PWM CONTROLLER

PRODUCTION DATA SHEET

CHARACTERISTIC CURVES

FIGURE 1. — DROPOUT VOLTAGE vs. TEMPERATURE

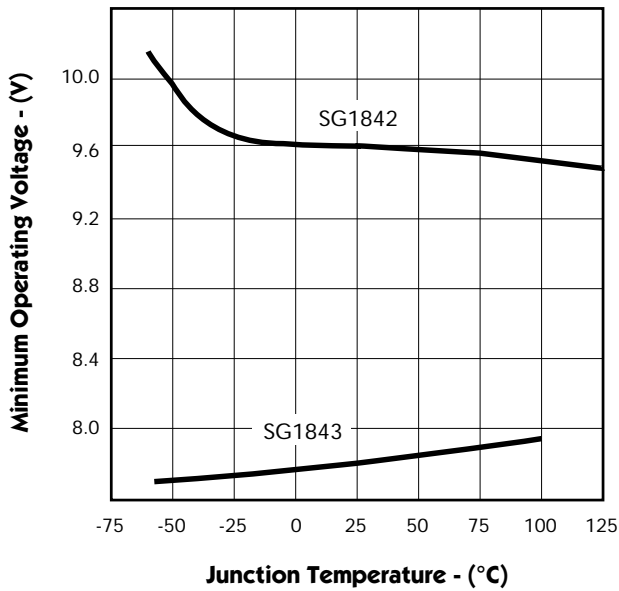

FIGURE 2. — OSCILLATOR TEMPERATURE STABILITY

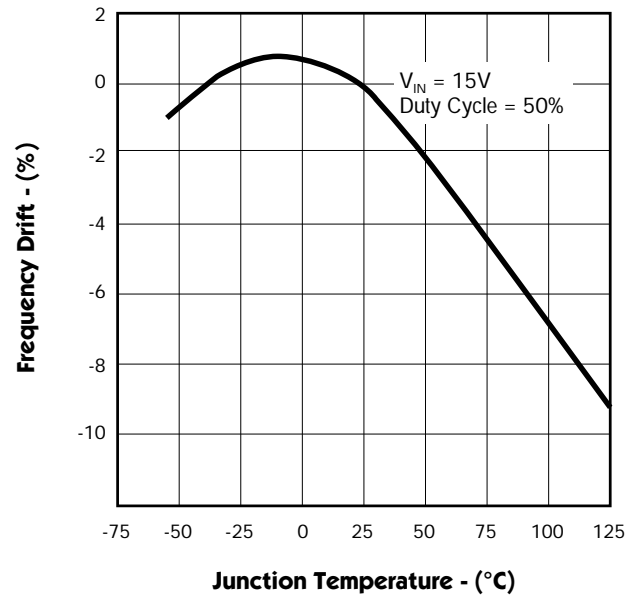

FIGURE 3. — CURRENT SENSE TO OUTPUT DELAY vs. TEMPERATURE

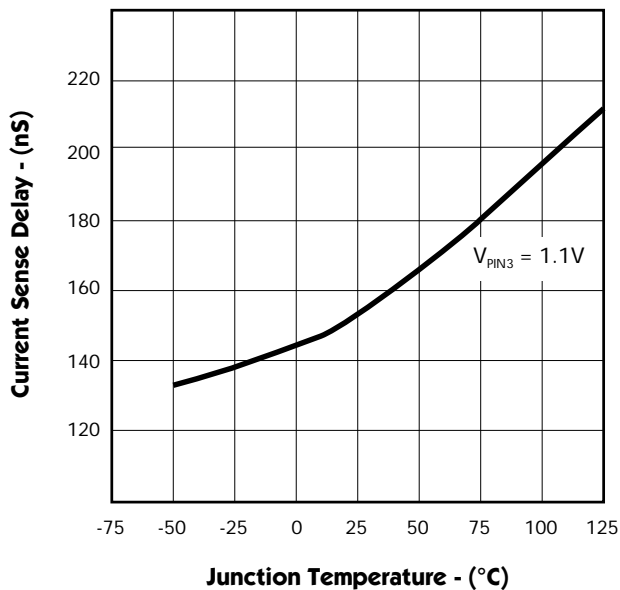
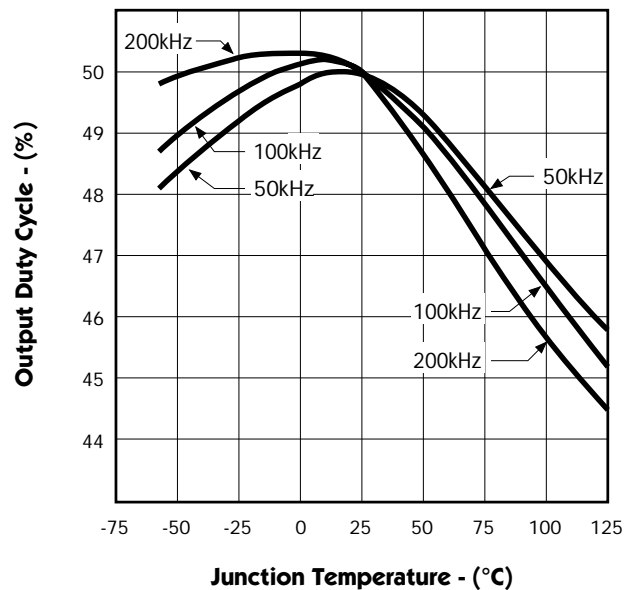

FIGURE 4. — OUTPUT DUTY CYCLE vs. TEMPERATURE



CHARACTERISTIC CURVES

FIGURE 5. — START-UP CURRENT vs. TEMPERATURE

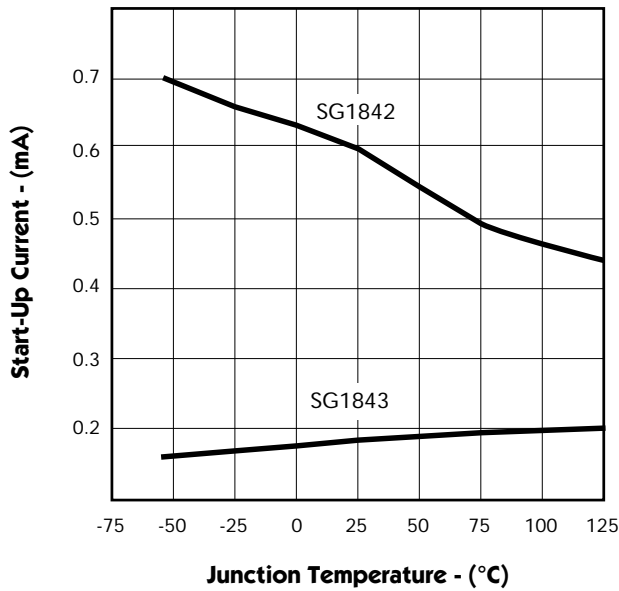

FIGURE 6. — REFERENCE VOLTAGE vs. TEMPERATURE

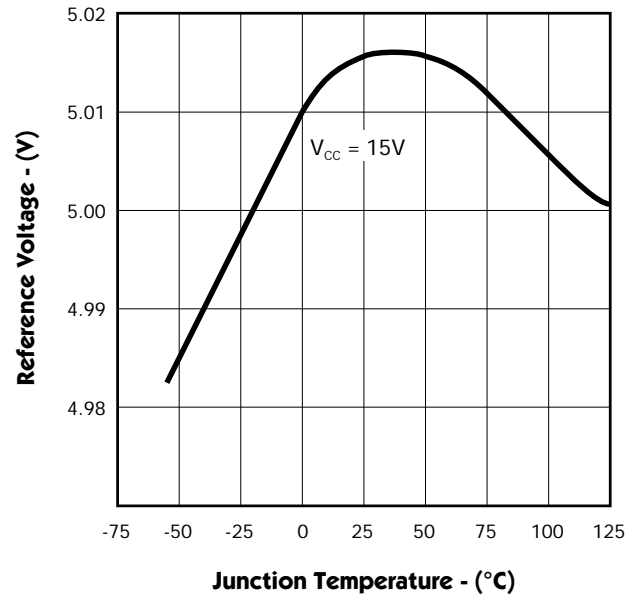

FIGURE 7. — START-UP VOLTAGE THRESHOLD vs. TEMPERATURE

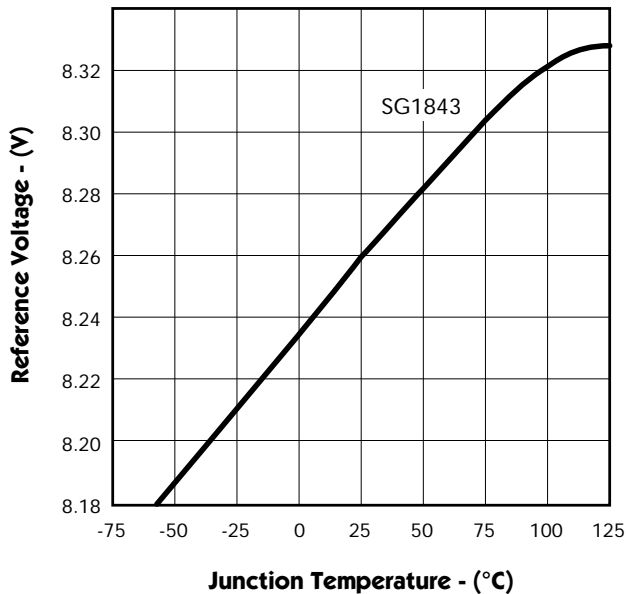
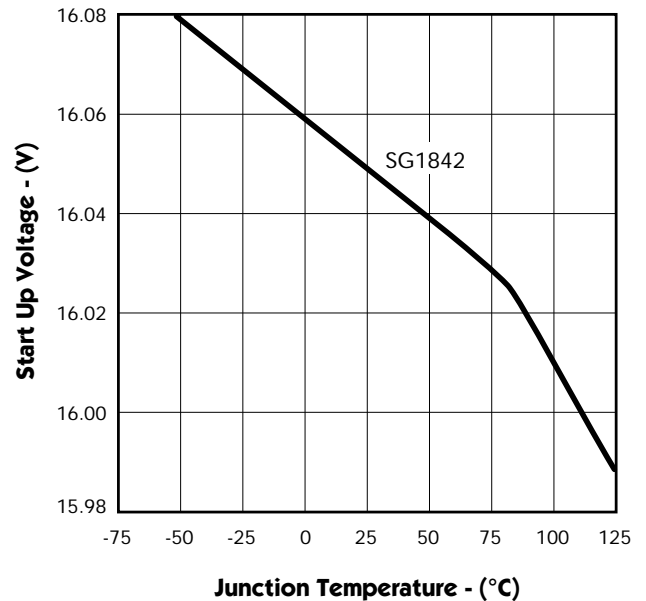

FIGURE 8. — START-UP VOLTAGE THRESHOLD vs. TEMPERATURE



CHARACTERISTIC CURVES

FIGURE 9. — OSCILLATOR DISCHARGE CURRENT vs. TEMPERATURE

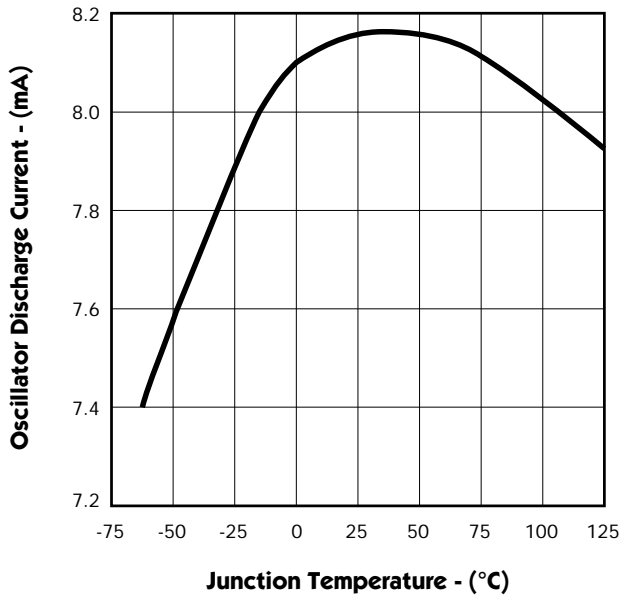

FIGURE 10. — OUTPUT SATURATION VOLTAGE vs. OUTPUT CURRENT & TEMPERATURE

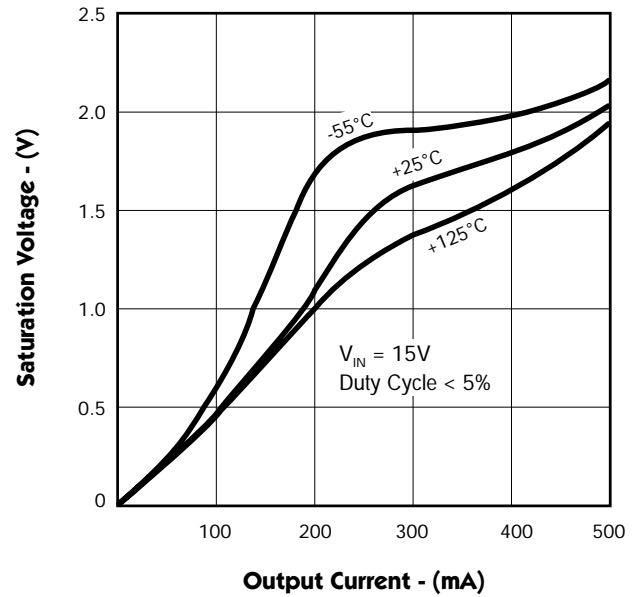

FIGURE 11. — CURRENT SENSE THRESHOLD vs. ERROR AMPLIFIER OUTPUT

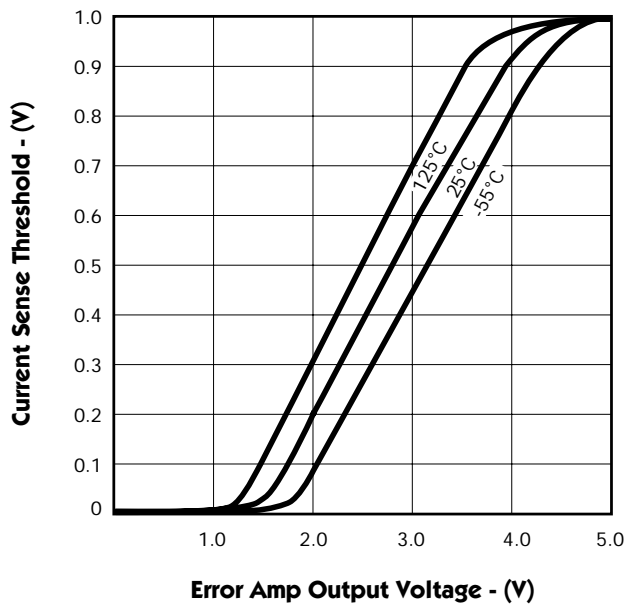
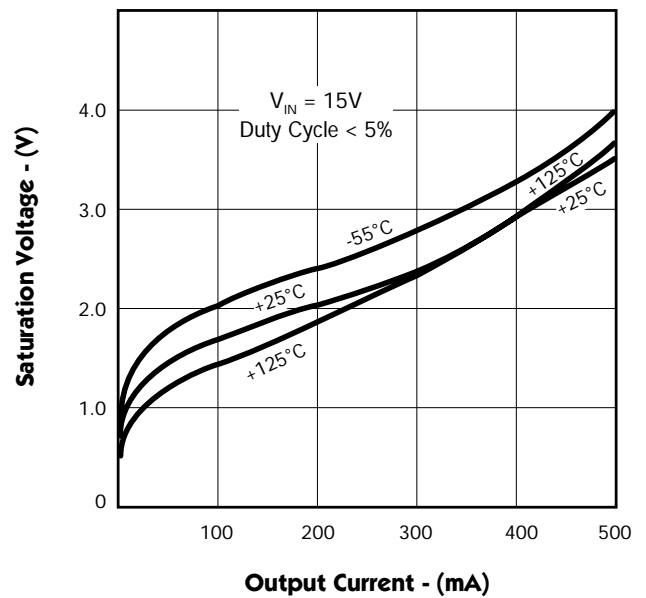

FIGURE 12. — OUTPUT SATURATION VOLTAGE vs. OUTPUT CURRENT & TEMPERATURE



APPLICATION INFORMATION

OSCILLATOR

The oscillator of the 1842/43 family of PWM's is designed such that many values of R_T and C_T will give the same oscillator frequency, but only one combination will yield a specific duty cycle at a given frequency.

Given: Frequency $\equiv f$
Maximum Duty Cycle $\equiv D_m$

$$\text{Calculate: } R_T = 267 \left[\frac{(1.76)^{1/D_m} - 1}{(1.76)^{(1-D_m)/D_m} - 1} \right] (\Omega)$$

where $.3 < D_m < .95$

$$C_T = \frac{1.86 * D_m}{f * R_T} (\mu\text{F})$$

For Duty-Cycles above 95% use:

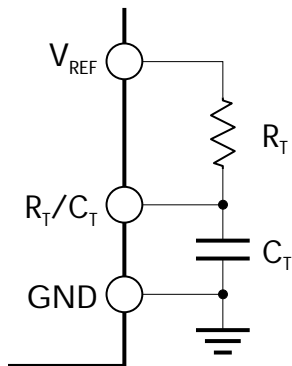

$$F \approx \frac{1.86}{R_T C_T} \text{ where } R_T \geq 5\text{k}\Omega$$

FIGURE 13 — OSCILLATOR TIMING CIRCUIT

A set of formulas are given to determine the values of R_T and C_T for a given frequency and maximum duty cycle. (Note: These formulas are less accurate for smaller duty cycles or higher frequencies. This will require trimming of R_T or C_T to correct for this error.)

Example:

A Flyback power supply requires a maximum of 45% duty cycle at a switching frequency of 50kHz. What are the values of R_T and C_T ?

Given: $f = 50\text{kHz}$
 $D_m = 0.45$

$$\text{Calculate: } R_T = 267 \left[\frac{(1.76)^{1/0.45} - 1}{(1.76)^{.55/0.45} - 1} \right] = 674\Omega$$

$$C_T = \frac{1.86 * 0.45}{50000 * 674} = .025\mu\text{F}$$

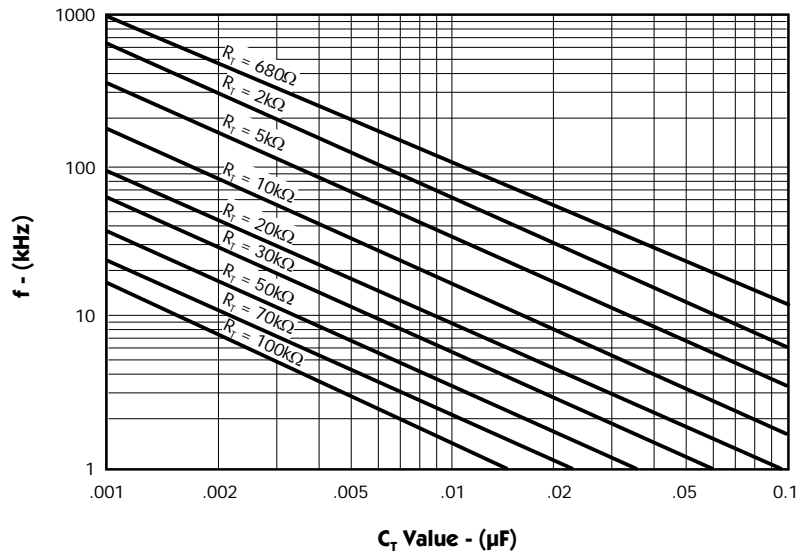

FIGURE 14 — OSCILLATOR FREQUENCY vs. R_T FOR VARIOUS C_T

CURRENT-MODE PWM CONTROLLER

PRODUCTION DATA SHEET

TYPICAL APPLICATION CIRCUITS

Pin numbers referenced are for 8-pin package and pin numbers in parenthesis are for 14-pin package.

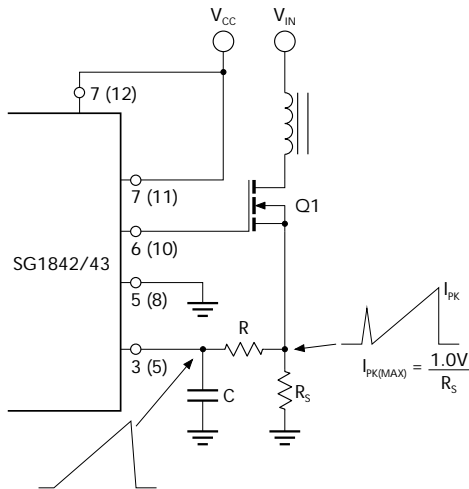

FIGURE 15. — CURRENT-SENSE SPIKE SUPPRESSION

The RC low pass filter will eliminate the leading edge current spike caused by parasitics of Power MOSFET.

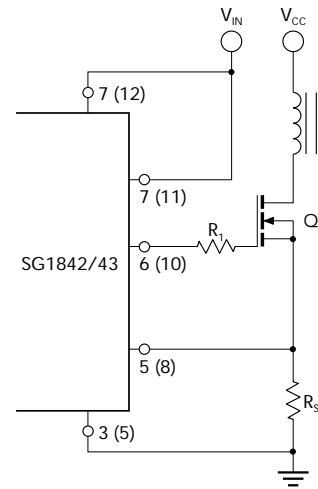

FIGURE 16. — MOSFET PARASITIC OSCILLATIONS

A resistor (R_1) in series with the MOSFET gate reduce overshoot and ringing caused by the MOSFET input capacitance and any inductance in series with the gate drive. (Note: It is very important to have a low inductance ground path to insure correct operation of the I.C. This can be done by making the ground paths as short and as wide as possible.)

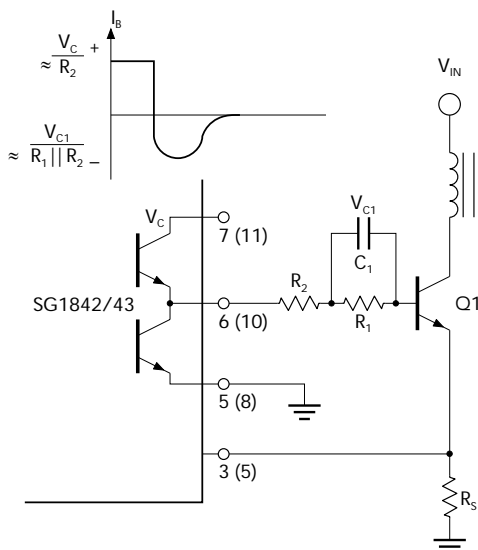
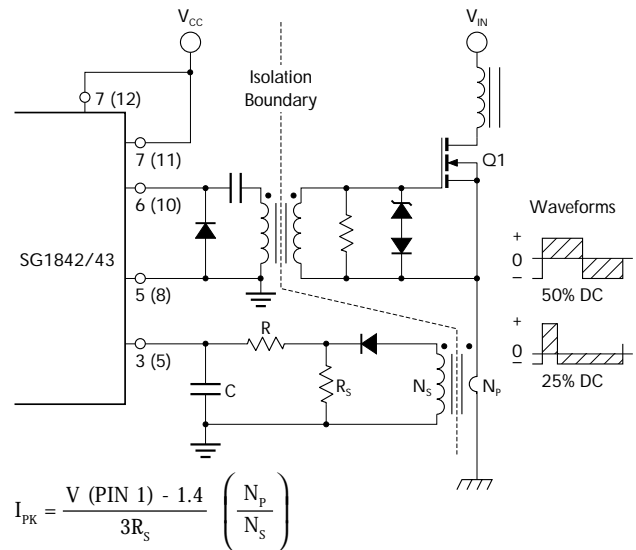

FIGURE 17. — BIPOLAR TRANSISTOR DRIVE

The 1842/43 output stage can provide negative base current to remove base charge of power transistor (Q_1) for faster turn off. This is accomplished by adding a capacitor (C_1) in parallel with a resistor (R_1). The resistor (R_1) is to limit the base current during turn on.



$$I_{PK} = \frac{V(\text{PIN } 1) - 1.4}{3R_s} \left(\frac{N_p}{N_s} \right)$$

FIGURE 18. — ISOLATED MOSFET DRIVE

Current transformers can be used where isolation is required between PWM and Primary ground. A drive transformer is then necessary to interface the PWM output with the MOSFET.

TYPICAL APPLICATION CIRCUITS (continued)

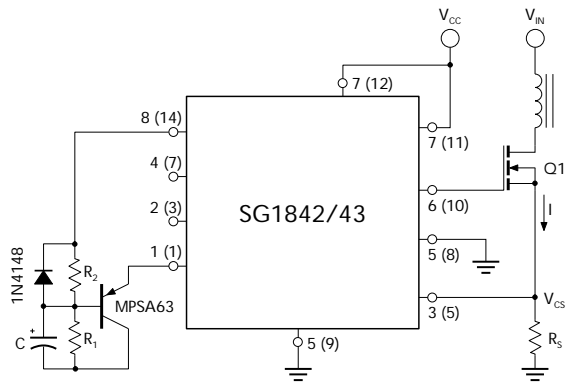

$$I_{PK} = \frac{V_{CS}}{R_S} \quad \text{Where: } V_{CS} = 1.67 \left(\frac{R_1}{R_1 + R_2} \right) \text{ and } V_{CS,MAX} = 1V \text{ (Typ.)}$$

$$t_{SOFTSTART} = -\ln \left[1 - \frac{V_{EAO} - 1.3}{5 \left(\frac{R_1}{R_1 + R_2} \right)} \right] \left(\frac{R_1 R_2}{R_1 + R_2} \right) C$$

where; V_{EAO} \equiv voltage at the Error Amp Output under minimum line and maximum load conditions.

FIGURE 19. — ADJUSTABLE BUFFERED REDUCTION OF CLAMP LEVEL WITH SOFTSTART

Softstart and adjustable peak current can be done with the external circuitry shown above.

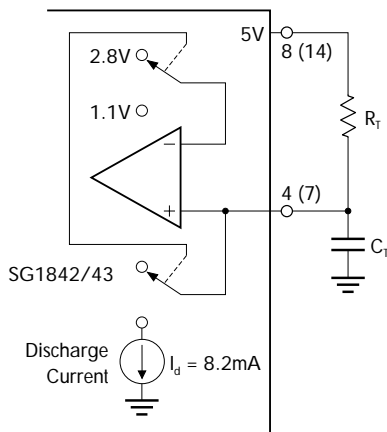
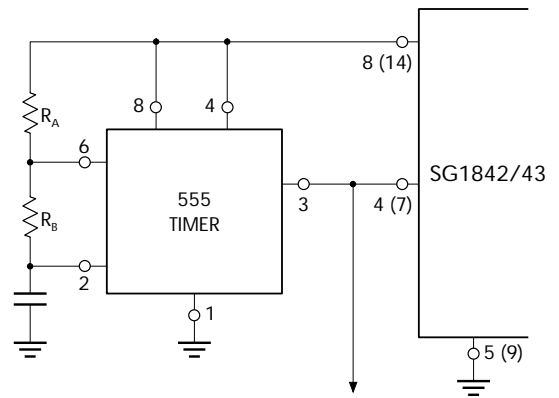

FIGURE 21. — OSCILLATOR CONNECTION

The oscillator is programmed by the values selected for the timing components R_T and C_T . Refer to application information for calculation of the component values.



$$f = \frac{1.44}{(R_A + 2R_B)C}$$

$$f = \frac{R_B}{R_A + 2R_B}$$

FIGURE 20. — EXTERNAL DUTY CYCLE CLAMP AND MULTI-UNIT SYNCHRONIZATION

Precision duty cycle limiting as well as synchronizing several 1842/1843's is possible with the above circuitry.

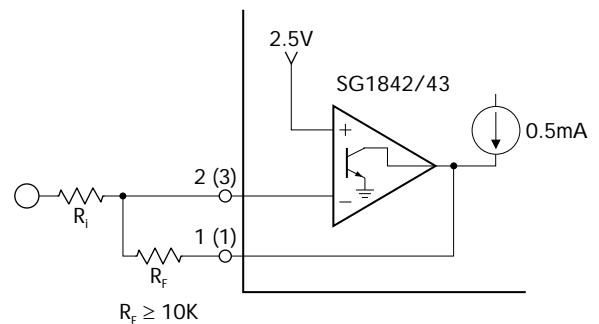

FIGURE 22. — ERROR AMPLIFIER CONNECTION

Error amplifier is capable of sourcing and sinking current up to 0.5mA.

TYPICAL APPLICATION CIRCUITS (continued)

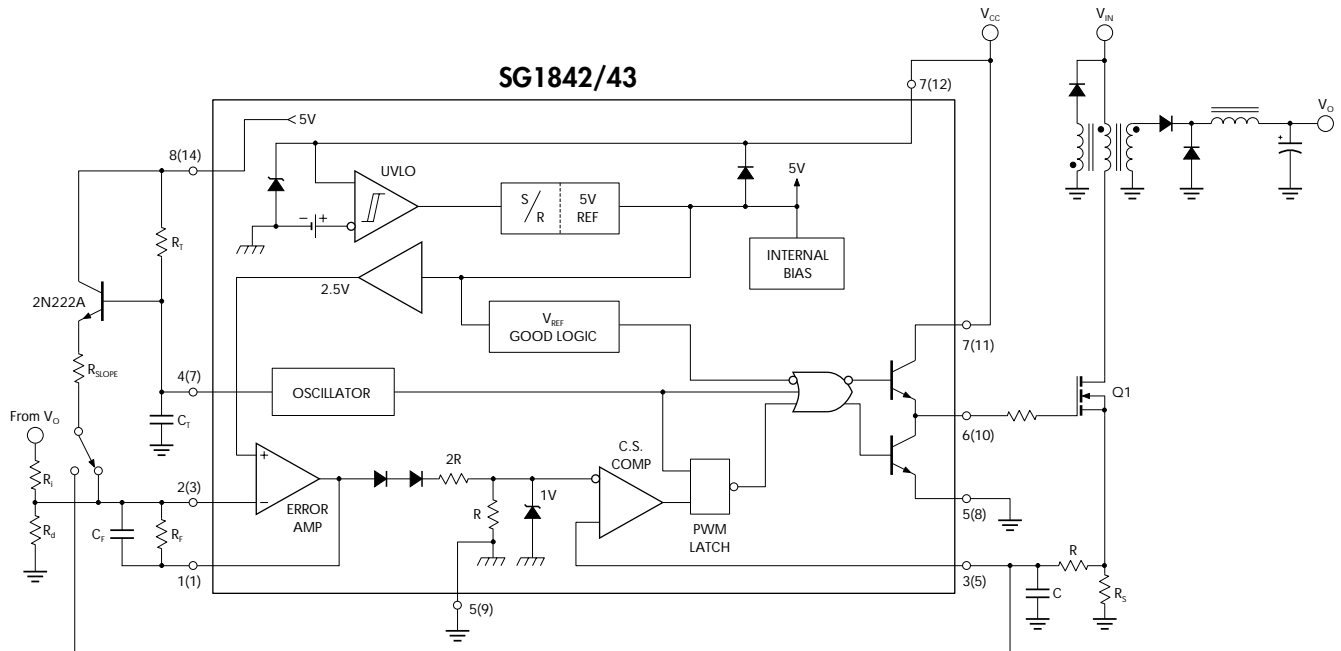

FIGURE 23. — SLOPE COMPENSATION

Due to inherent instability of current mode converters running above 50% duty cycle, a slope compensation should be added to either current sense pin or the error amplifier. Figure 23 shows a typical slope compensation technique.

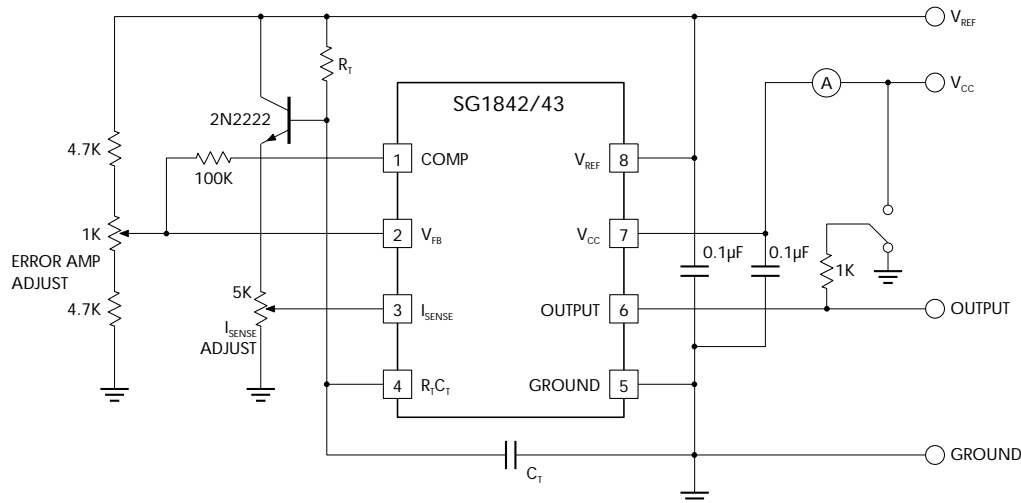

FIGURE 24. — OPEN LOOP LABORATORY FIXTURE

High-peak currents associated with capacitive loads necessitate careful grounding techniques. Timing and bypass capacitors should be connected to pin 5 in a single point ground. The transistor and 5k potentiometer are used to sample the oscillator waveform and apply an adjustable ramp to pin 3.

SG1842/SG1843 Series

CURRENT-MODE PWM CONTROLLER

PRODUCTION DATA SHEET

TYPICAL APPLICATION CIRCUITS (continued)

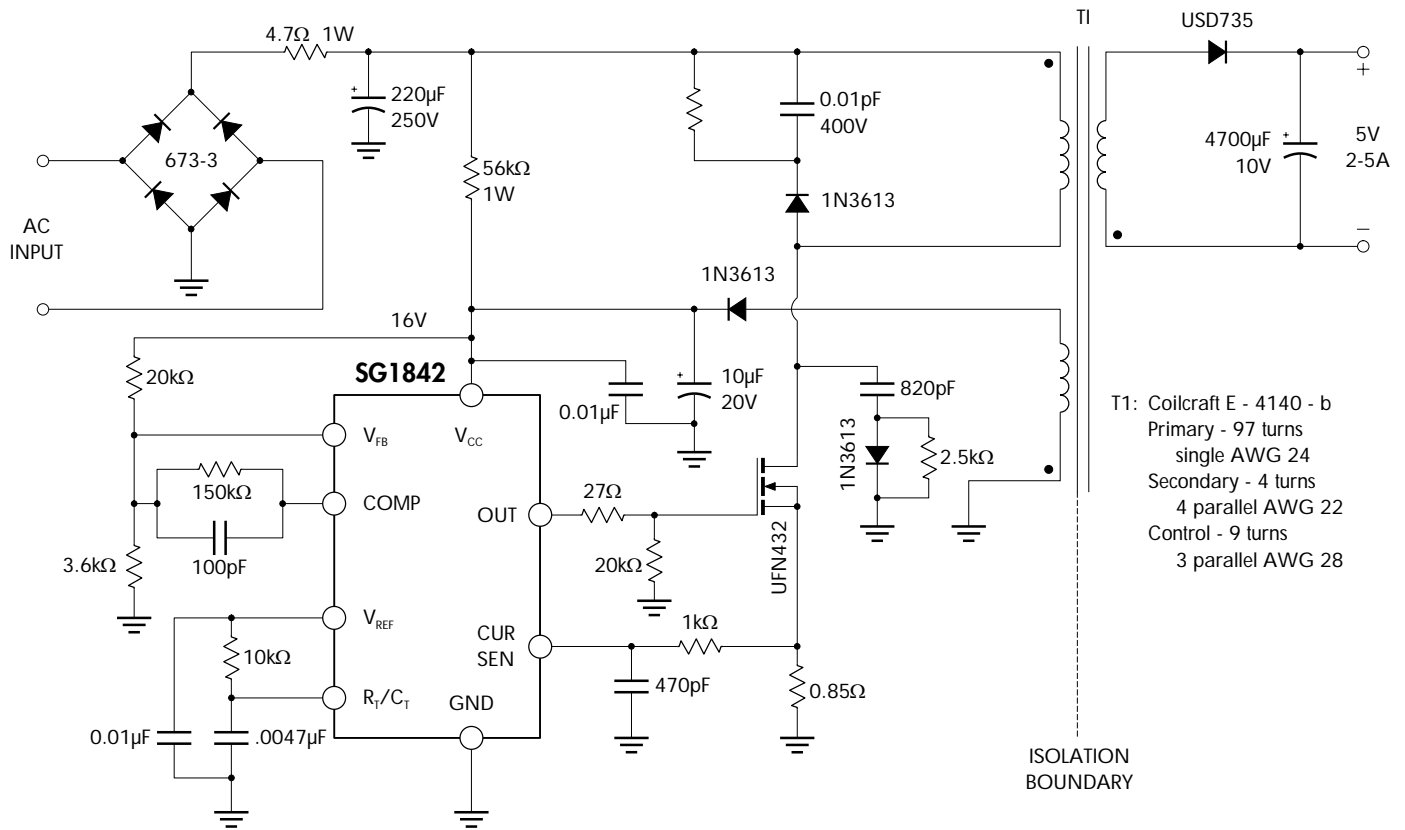

FIGURE 25. — OFF-LINE FLYBACK REGULATOR

SPECIFICATIONS

Input line voltage:	90VAC to 130VAC
Input frequency:	50 or 60Hz
Switching frequency:	40KHz \pm 10%
Output power:	25W maximum
Output voltage:	5V \pm 5%
Output current:	2 to 5A
Line regulation:	0.01%/V
Load regulation:	8%/A*
Efficiency @ 25 Watts,	
$V_{IN} = 90VAC$:	70%
$V_{IN} = 130VAC$:	65%
Output short-circuit current:	2.5Amp average

* This circuit uses a low-cost feedback scheme in which the DC voltage developed from the primary-side control winding is sensed by the SG1842 error amplifier. Load regulation is therefore dependent on the coupling between secondary and control windings, and on transformer leakage inductance.